

# Wall Mount Rack

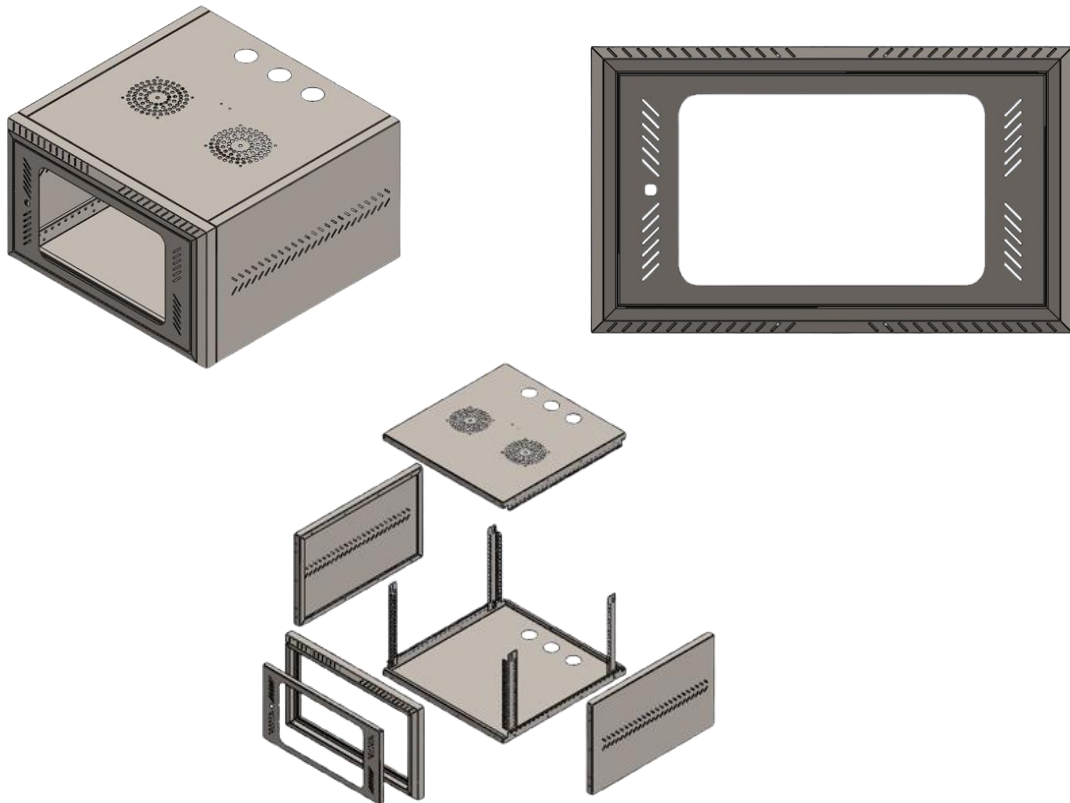

**Genius** Wall Mount Rack is a compact, EIA-310 compliant enclosure built with rigid bolted CRCA steel construction for high strength and stability. It features a lockable toughened glass front door with ventilation slots and Locking Provision for secure access and continuous equipment monitoring. Ventilated top and bottom covers support efficient airflow, with provision for 90 CFM cooling fans and dust-controlled cable entry options. Four adjustable 19-inch mounting rails with universal hole pattern and U-marking ensure precise and flexible installation. Finished with 60–80 micron epoxy-polyester coating and compliant with IP20, IK08, and ISO standards, it delivers reliable performance and durability

## Key Features

- Conforms to DIN 41494 or Equivalent EIA /ISO / EN Standards
- Four adjustable 19" EIA-310 rails with 10 mm square holes, universal pitch (12.7–15.875–15.875 mm) and 44.45 mm spacing per DIN 41494
- Rigid all-round bolted steel construction with precision-formed, deburred components and concealed fasteners, featuring a reinforced front frame providing diagonal strength and torsional rigidity
- Lockable toughened glass door with ventilation for secure equipment monitoring
- Front Frame with Additional Ventilation for all directional air flow
- Ventilated top & bottom covers. 1 / 2 Fan Mount provision on top cover
- Cable entry top & bottom with rubber grommets; optional brush cutout
- Ventilated side for better ventilation
- High-quality epoxy-polyester powder coating (60–80 microns) for long life
- Multiple Rack Accessories are available as optional
- Maximum load carrying capacity ranges from 30 kg to 70 kg depending on rack Configuration
- Complies with IS 9606, DIN 41494 & IEC 60297; IP20 (IEC 60529) & IK08 (IEC 62262) rated; manufactured under ISO 9001, 45001 & 14001 systems
- CE Certified & RoHS Compliant
- Genius Network comprehensive warranty for one year

## Product Specification

Material	CRCA Steel
Construction	CKD / Assembled
Side panel	Integrated Side
Top Cover	Ventilated top includes fan provision Cable entry via rubber grommets
Bottom Cover	Ventilated Bottom; Cable entry via rubber grommets
Front Door	Lockable toughened glass door with ventilated frame
Standard Mounting	DIN standard 10 mm square slots. Hole Pattern, (12.7 mm – 15.875 mm – 15.875 mm)
Finishing	Epoxy polyester powder coated
Standard Color	Grey RAL 7035 & RAL 7037 (Dual Tone) Black RAL 9005
Static Load	30 Kg to 70 Kg (Depending on Rack Configuration)

## Dimensional Specification

Product Series	Height (H)	Usable Height (h)	Width (W)	Usable Width (w)	Depth (D)	Usable Depth (d)
4U	600 x 450	270	4U	600	19"	358
	600 x 500	270	4U	600	19"	408
	600 x 600	270	4U	600	19"	508
6U	600 x 450	359	6U	600	19"	358
	600 x 500	359	6U	600	19"	408
	600 x 600	359	6U	600	19"	508
9U	600 x 450	492	9U	600	19"	358
	600 x 500	492	9U	600	19"	408
	600 x 600	492	9U	600	19"	508
12U	600 x 450	626	12U	600	19"	358
	600 x 500	626	12U	600	19"	408
	600 x 600	626	12U	600	19"	508
15U	600 x 450	759	15U	600	19"	358
	600 x 500	759	15U	600	19"	408
	600 x 600	759	15U	600	19"	508

Note - All dimensions are in mm unless otherwise specified. 1U Equals to 44.5mm/1.75"

## Standards, Certifications & Compliances

- RoHS Compliant
- Compliance with DIN 41494
- Compliance with 19-inch rack standard EIA-310
- Compliance with IEC 60297 for Cabinet
- CE Certified
- Compliance with IEC 60529 / EN 60529 for IP 20 rating
- Compliance with IEC 62262 / EN 62262 for IK08 Impact Resistance
- Compliance with ISO 9227 (NSS) and IEC EN 60068-2-11 (Ka) for 168 hours salt spray test.
- Compliance with Rusting degree Ri1 as per ISO 4628-3; corrosion propagation  $\leq 1$  mm per ISO 4628-8
- Compliance with IS 9606-1980 for welding Quality
- Production in ISO 9001, ISO 14001 & ISO 45001 certified Manufacturing facilities

## Ordering Information

**GRWMAABBXXY**



Sample product Description - Genius Wall Mount 06U Rack 600\*450 Fixed Grey CKD

## Wall Mount Rack Accessories

### Cable manager



Genius cable managers are available in loop style and closed loop (PVC) designs, ensuring efficient cable routing and organization in racks. Offered in 1U and 2U options, they support flexible and secure cable management for various applications. Finished in black and fully assembled, they provide a neat, structured, and professional cabling solution



Part Number	Product Description
GRCOLM1BXX	Genius Cable manager Loop style Black 1U
GRCCCP1BXX	Genius Cable manager Closed Loop Black PVC 1U
GRCCCP2BXX	Genius Cable manager Closed Loop Black PVC 2U

## Cantilever Shelves

Genius Cantilever Shelves is designed for sturdy support of non-rack mount equipment, ensuring reliable performance in rack environments. Available in 1U (255 mm depth) and 2U (400 mm depth) variants, it suits diverse installation needs. Offered in Black and Grey color options, it blends seamlessly with standard rack systems



Part Number	Product Description
GRSH1U2BCS	Genius Cantilever Shelves 19" 1U 255 Depth Black
GRSH2U4BCS	Genius Cantilever Shelves 19" 2U 400 Depth Black
GRSH1U2GCS	Genius Cantilever Shelves 19" 1U 255 Depth Grey
GRSH2U4GCS	Genius Cantilever Shelves 19" 2U 400 Depth Grey



## Power Distribution Unit



Genius 19" Power Distribution Units (PDU) are designed for reliable power management in rack environments, available in 4 and 6 socket configurations with DPST switch options. The range also includes a 6-socket model with 06/16A rating and 16A MCB for enhanced protection and flexibility. Fully assembled in a durable black finish, these PDUs ensure safe, efficient, and organized power distribution.

Part Number	Product Description
GRPDHP06A4DSB	Genius Power Distribution Unit 19" 06A 4 Socket DPST Switch Black
GRPDHP06A6DSB	Genius Power Distribution Unit 19" 06A 6 Socket DPST Switch Black
GRPDHP16A616MB	Genius Power Distribution Unit 19" 06/16A 6 Socket 16A MCB Black

## Hardware Kit

Genius Hardware Kit includes M6 screws, cage nuts, and washers for secure and reliable rack mounting. Available in convenient packs of 10, and 20 to suit various installation requirements



Part Number	Product Description
GRHW1SSCWXXXX	Genius Hardware Kit Pack of 10
GRHW2SSCWXXXX	Genius Hardware Kit Pack of 20

## Rack Cooling Fan Unit



Genius Cooling Fan Units deliver efficient airflow with 90 CFM performance, ensuring optimal heat dissipation in rack systems. Available in 1 or 2 fan configurations, they suit varying cooling requirements

Part Number	Product Description
GRFN91FXXXX	Genius 90 CFM Fan 1Nos
GRFN92FXXXX	Genius 90 CFM Fan 2Nos

Note – Illustrations shown in this datasheet are for reference only. Actual product may vary